



KNAUFCEILING
Solutions

DATASHEET

HERADESIGN® Wallcoustic Element



The HERADESIGN® Wallcoustic Element is a magnesite bonded wood wool acoustic wall panel bonded to a 50mm or 100mm acoustic lining.

- Available in four different sizes with a HERADESIGN® Superfine surface
- Delivered as a kit making it quick and easy to install

Surface		HERADESIGN® Superfine									
Thickness		25mm									
Dimensions and weights	 	HERADESIGN® Wallcoustic Element Format (mm) L x B x H	Mineral wool lining (mm)				Weight (kg/Element)				
		1200 x 600 x 125	100				18.30				
		1200 x 600 x 75	50				15.90				
		600 x 600 x 125	100				10.50				
		600 x 600 x 75	50				8.40				
System		The wall absorber is delivered in one piece, ready for installation, and can be quickly mounted onto a supporting vertical substrate in any position using the included wooden frame.									
Fire reaction		Euroclass B-s1,d0 according EN 13501-1									
Sound absorption		HERADESIGN® Wallcoustic Element Format (mm) L x W x H	HERADESIGN® Acoustic lining		Equivalent absorption area A_{obj} [m²] Frequencies [Hz]						
			Thickness (mm)	(kg/m ³)	125	250	500	1000	2000	4000	
		1200 x 600 x 125	100	50	0.60	1.30	1.40	1.20	1.10	1.10	
		1200 x 600 x 75	50	50	0.20	0.80	1.10	0.90	1.00	0.90	
		600 x 600 x 125	100	50	0.30	0.70	0.80	0.70	0.60	0.60	
		600 x 600 x 75	50	50	0.10	0.40	0.60	0.50	0.50		
Humidity resistance		Not suitable for use in indoor swimming pools, underground garages and outdoor areas.									
Cleanability											
Colours		Standard colours		vd Vario Design colours							
		White Similar to RAL 9010	Beige Natural tone 13	Granite	Steel	Green Marble	Copper	Oak	Brass	Sandstone	Concrete
		<ul style="list-style-type: none"> • Other colours from popular RAL and NCS colour systems are available. • Deviations in colour and visual appearance may occur due to the rough fibre and panel surface. 									
Sustainability											

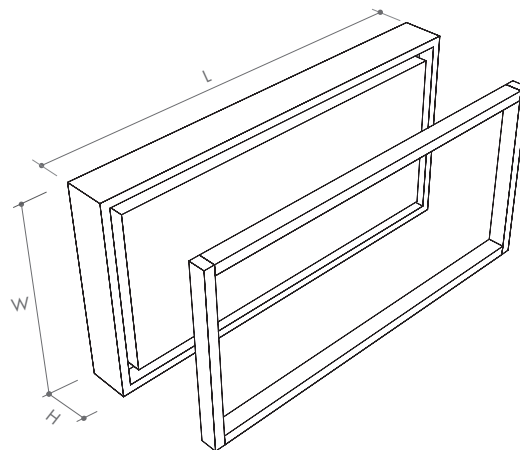

Products may vary from country to country. Please contact your local sales representative. For further information and legal notice, please visit our website.